

표준 도면 (Applied DIM. No.)	비고 (Remarks)
1	
2	

MARK	DATE	DETAIL OF REVISION	CHECK	APP.
▲				
▲				

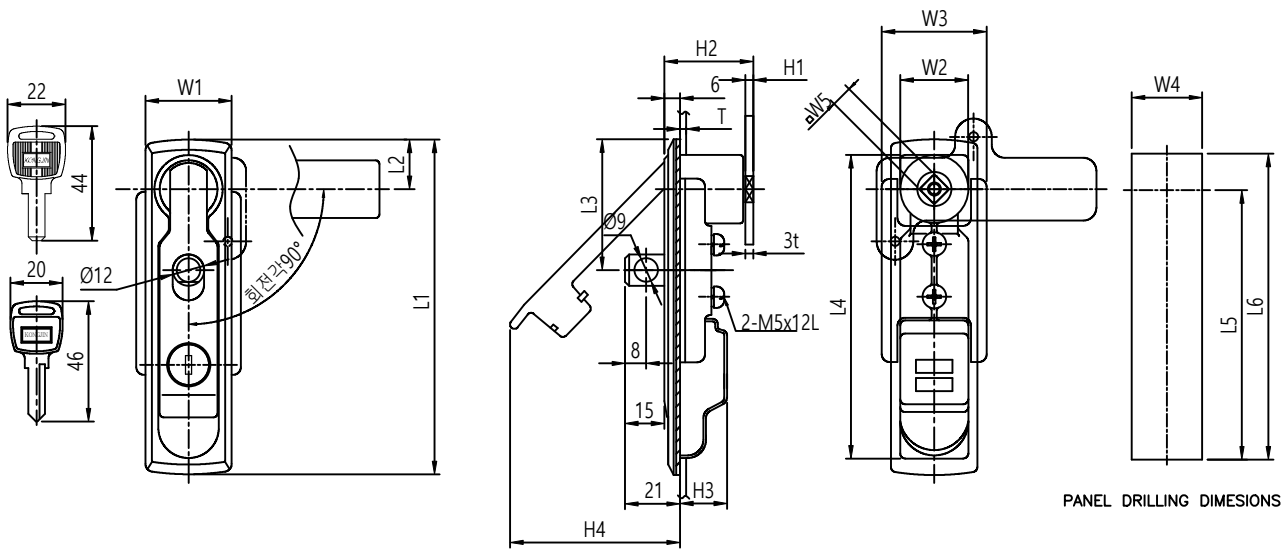

PANEL DRILLING DIMENSIONS.

제품명	L1	L2	L3	L4	L5	L6	H1	H2	H3	H4	W1	W2	W3	W4	W5	Net weight(g)
SBH-HF-88W-2KB	128	19	50	116	102	117	3	34	18	65	33	26	40	27	8	324
SBH-HF-88W-2KC	128	19	50	116	102	117	3	34	18	65	33	26	40	27	8	324
SBH-HF-88W-3KB	153	22	73	140	125	141	6	40	20	84	38	29	47	30	10	480
SBH-HF-88W-3KC	153	22	73	140	125	141	6	40	20	84	38	29	47	30	10	480

GENERAL TOLERANCE

SIZE	A LEVEL	B LEVEL	C LEVEL
1-4	±0.07	±0.10	±0.15
5-10	±0.07	±0.10	±0.15
11-25	±0.10	±0.15	±0.20
26-50	±0.15	±0.20	±0.30
51-100	±0.20	±0.30	±0.40
100-1000	±0.30	±0.40	±0.50

부품번호 Part No.	변호번호 No.	명칭 Part Name	개수 Q't'y	재질	비고 Remarks
DATE	SCALE: 1/1	MODEL:			
		TITLE:			
		MODEL No.			
		DWG No.			

SAMO